

2017 December

Power Supply for Desktop PC

HPCSA-700P series



ATX Power Supply

CONTINUOUS MAX.: 600 W

PEAK POWER: 700 W

Industrial grade ATX power supply HPCSA-700P series



Continuous: 600W Peak: 700W

A new ATX power supply HPCSA-700P is now available. HPCSA-700P is a large capacity, high efficiency ATX power supply unit with the maximum efficiency of 89%. Compared with Nipron's 650 W power supply units, its depth is 30 mm shorter while the power capacity has been increased. In addition, the standby power consumption is held to 0.1 Wtyp, satisfying the ErP Directive. Also, there is a plan to introduce a variation with various features supporting IoT, enabling life expectancy prediction, operational status monitoring, etc.

IoT compatible model will be in the lineup. Such matters are possible!

- Forecast of life
- I²C communication function
- Output voltage rising adjustment
- Monitoring function
- Variable setting function of overcurrent protection circuit

Outline of product

High quality and reliability

- Parts layout ensuring superior quality and high reliability

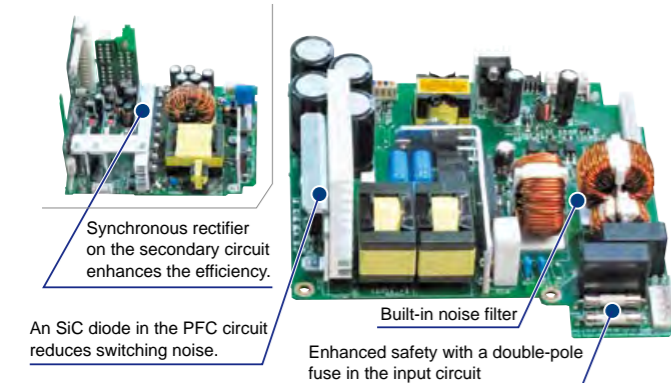

High-efficiency circuit reduces amount of heat generation

It achieves maximum efficiency of 89% typ. It reduces significantly power loss, minimizes power consumption during operation of equipment and contributes to mitigation of environmental load.

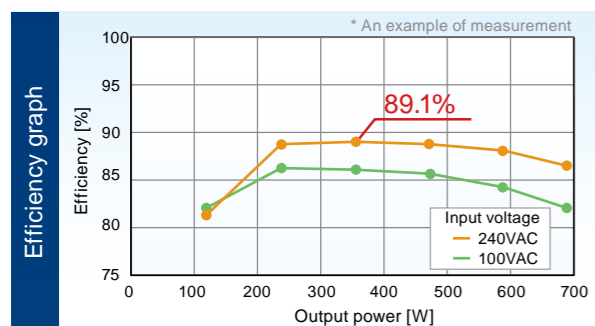

Low noise and low leakage current are offered

While reducing the leakage current, the conducted emission of even a single power supply unit clears the VCCI Class B regulation thanks to the enhanced noise filter circuit, optimization of parts layout, etc. It is not necessary to install an external noise filter, leading to a reduction in the cost and man-hour.

Conducted emission characteristics

[100 VAC with the rated load] * An example of measurement

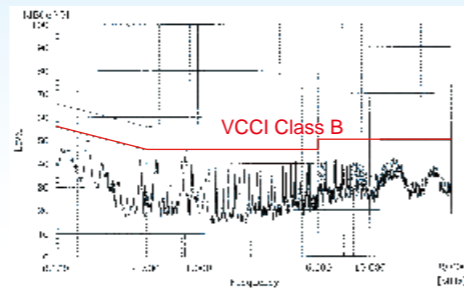

Leakage current

[At the rated load] * An example of measurement

Input voltage	100 VAC	240 VAC
Leakage current value	0.1 mA	0.24 mA

Other features

- Low standby power consumption of 0.1 Wtyp (ErP Directive compatible)
- Minimum load current 0A for all outputs
- A temperature controlled variable speed fan is adopted
- Double sided through hole printed circuit board adopted

IoT compatible model HPCSA-700P-E2S-IoT will be in the lineup

* For details, please contact us.

Forecast of life

Operating time is weighed by monitoring operating conditions including fan speed, internal temperature of a power supply unit, load condition, etc. and remaining life is forecasted.

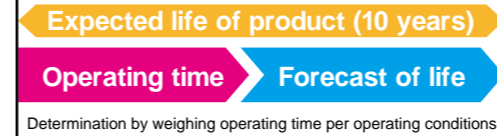

Monitoring function

Respective input and output conditions inside a power supply unit are recorded and output to the outside by communication function.

- Respective output voltages and currents
 - Input voltage and input power
 - Fan speed
 - Operating temperature
 - State of abnormality protection operation, etc.
- Uniform control of input and output conditions
Records of failures in a system are kept.

I²C communication function

It supports communication according to I2C standard which has rich experience as internal communication for industrial machinery, etc. It provides highly reliable high-speed communication. With an additional optional communication board, it can respond to various requirements including USB, RS-232C, etc.

Variable setting function of overcurrent protection circuit

Standard setting for overcurrent protection (OCP) is so made as to meet with the upper limit of respective systems. For example, however, "in the case that +3.3 V system and +5 V system are seldom used," it is possible to make setting from external PC that overcurrent protection operates with smaller current than standard. Thus, it is possible to provide optimized protection for equipment.

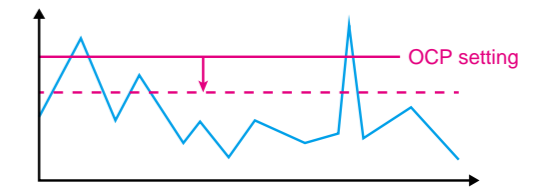

Output voltage rising adjustment

Against a problem of compatibility between PC and a power supply unit which may occur rarely due to difference in rising timing of output voltages, it is possible to make setting from external PC that rising timing is individually adjusted and thus cause can be examined and a countermeasure can be taken smoothly.

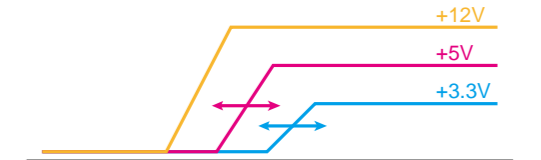

Features of power supply unit compatible with IoT

IoT (Internet of Things) is a system in which everything is connected with internet. Connection of things with internet enables remote measurement, recognition, control, etc., grasping and improving rate of operation for manufacturing facilities, identification of failure spot of production facilities, improvement of product quality, energy management, etc. Since HPCSA-700P of our company allows for monitoring of various voltages, currents and abnormalities and life forecast, it enables early detection of abnormality of respective devices, avoiding stop of a device due to life (Improvement of RAS function), grasping load factor of respective equipment from power consumption, peak power reduction control, etc.

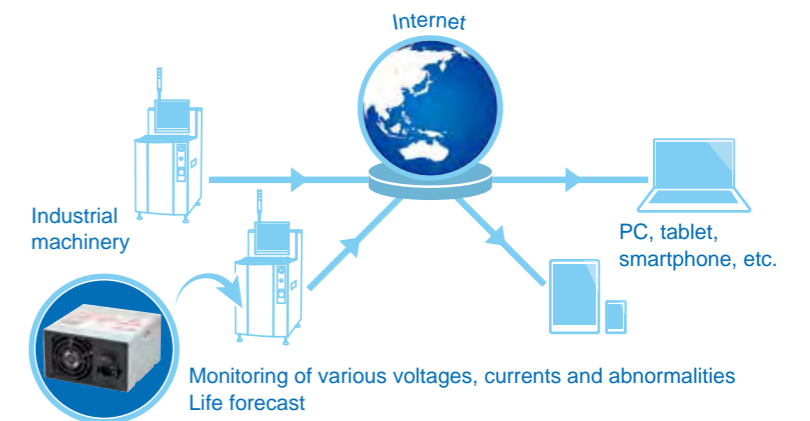

Expansion of features supported

+24 V/+48 V output*

The HPCSA-700P series allows the user to add a +24 V or +48 V output, which is not offered in ordinary ATX power supply units. Therefore, the unit may be used for both control and motive power, eliminating the necessity to prepare an additional single output power supply. In addition, the +24 V/+48 V circuit is isolated from the ATX outputs to enable a stable operation of the PC even if a parallel connection is made to a device with large noise, such as a motor.

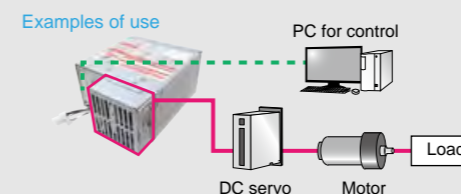

A countermeasure against instantaneous power failure / blackout*

If it is connected with a capacitor pack or a battery package, it allows for a countermeasure against instantaneous power failure / blackout.

- Capacitor pack
- Battery pack

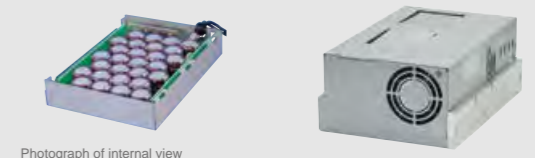

Photograph of internal view

* Please contact Nipron since these options are not standard models.

Desktop PC Power Supply HPCSA-700P Series

Large capacity, high efficiency ATX power supply!



HPCSA-700P-E2S

RoHS Directive

ATX
Continuous 600W Peak 700W

Model	Description
HPCSA-700P-E2S	-
HPCSA-700P-E2S-IoT	Supports IoT (with I ² C communication function) model

Model Name Coding	① Series name	④ EPS output	⑦ Supports IoT (with I ² C communication function)
HPCSA-700P-E2S-IoT	② Output power	⑤ +3.3V output equipped	
① ② ③ ④ ⑤ ⑥ ⑦	③ Peak power available	⑥ Standard	

Features

- Double-sided through hole PCB suitable for industrial use.
- High efficiency achieved by the use of a synchronous rectifier and SiC diode
- Achieved low noise and low leakage current
The conducted emission VCCI ClassB leakage current is 0.2mA or less (at 100VAC)
- Low standby power specification which supports ErP directive (0.1 Wtyp)
- Minimum load current 0A for all outputs
- By building in the thermal-sensing variable speed fan, noise reduction can be realised.
- Supports IoT (with I²C communication function) model is lineup

Safety standard	UL	CSA	EN	CE	CCC
Reliability grade	HFA	FA	HOA	OA	

Function



Input

AC input	85-264 VAC (Worldwide range, with PFC)
----------	--

Output

Output voltage	+3.3V	+5V	+12V1	+12V2	+12V3	-12V	+5VSB
Max. current/ max. power (continuous)	16A Total 90W	16A	18A	18A	18A	1A	2A Total 600W
Peak current/ peak power (within 5s)	20A Total 120W	20A	25A	25A	25A	1A	3A Total 700W
Min. current	0A	0A	0A	0A	0A	0A	0A

Dimension

W×H×D (mm)	150×85×150
------------	------------

Output connector (optional component)

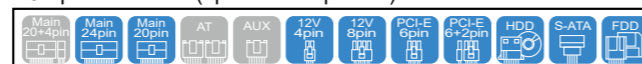

General Specification (Items are provided at normal temperature and humidity unless otherwise specified.)

Items	Specification	Measurements conditions, etc.	
AC Input	Rated Voltage	100-240VAC (85~264VAC)	Worldwide range *See <Fig.1> Low input voltage derating below.
	Input Frequency	50/60Hz	Frequency range 47-63Hz
	Efficiency	84% typ (100VAC), 88% typ (240VAC) *Characteristic data: Fig.5	At rated output
	Power Factor	96% min. (100VAC), 90% min. (240VAC) *Characteristic data: Fig.6	
	Inrush Current	15A peak (100VAC), 36A peak (240VAC) *Characteristic data: Fig.7	At rated output, cold start (25°C) Reclosing interval of 1 min or longer
Output	Input Current	7.1A typ (100VAC), 2.9A typ (240VAC) *Characteristic data: Fig.5	At rated output
	Rated Voltage	+3.3V +5V +12V1 +12V2 +12V3 -12V +5VSB	Reference value during the measurement of input/output characteristics
	Rated Current	10A 10A 15A 15A 12A 12A 0.5A 1A	Max. output power: 600W Refer to the derating condition
	Max. Current / Power	16A 16A 18A 18A 18A 1A 2A 52.8W 80W 216W 216W 216W 12W 10W 90W max. 600W max. 10W	
	Peak Current / Power	20A 20A 25A 25A 25A 1A 3A 66W 100W 300W 300W 300W 12W 15W 120W max. 700W max. 15W 700W max.	Peak output power: 700W Time: 5 sec or less Duty ratio of repetitive load: 10% or less (Refer to <Fig.2> Duty Ratio below.)
	Min. Current	0A 0A 0A 0A 0A 0A 0A	*Refer to <Fig. 4> the minimum load condition below.
	Total Voltage Accuracy (%)	±5 max. ±5 max. ±5 max. ±5 max. ±5 max. ±5 max. ±5 max.	The point of voltage measurement is the output connector terminal on the power supply and the voltage drop due to the contact resistance of paired connector is not included.
	Max. Ripple Voltage (mVp-p)	50 max. 50 max. 80 max. 80 max. 80 max. 80 max. 50 max.	Two wires are coming out from the output connector and connected into one at the edge. 47µF electrolytic capacitor and 0.1µF ceramic capacitor are placed on it and it is measured.*Characteristic data: Fig. 18
	Max. Spike Voltage (mVp-p)	100 max. 100 max. 200 max. 200 max. 200 max. 200 max. 100 max.	
	Protection	Over Current Protection	OCP point (A) 5 sec or longer after exceeding the max. current 21 min. 21 min. 26 min. 26 min. 26 min. Short protection
Method		All outputs of +3.3V, +5V, +12V1, +12V2, +12V3 and -12V are shut down.	All outputs shut down with a +5VSB short-circuit (automatic recovery)
Recovery		Reclosing AC input, or switching PS_ON# signal from 'H' to 'L'	AC reclosing period of 1 min or longer
Over Voltage Protection	OVP point (V)	3.8-4.3 5.7-7.0 13.4-15.6 - - 5.7-7.5	
	Method	All outputs of +3.3V, +5V, +12V1, +12V2, +12V3 and -12V are shut down.	All outputs shut down
	Recovery	Reclosing AC input, or switching PS_ON# signal from 'H' to 'L'	AC reclosing period of 1 min or longer. The period shall be 10 mins or longer during the OVP operation of +5VSB line.
Environment	Operating Temp./ Humidity	0-60°C*/10-90%	*Refer to <Fig.3> Temperature derating below. There shall be no condensation
	Storage Temp./Humidity	-20-70°C/10-95%	There shall be no condensation
	Vibration	Acceleration amplitude: 2G (10-55Hz), Sweep cycles: 10 times in the X-, Y-, and Z-axes	Follow JIS-C-60068-2-6 at no operation
	Mechanical Shock	Lift one bottom edge up to 50mm and let it fall. Number of bumps: 3 each of 4 edges	Follow JIS-C-60068-2-31 at no operation
Insulation	Dielectric Strength	AC input - FG/DC output: 1500 VAC for 1 minute	Cut-off current 10mA
	Insulation Resistance	AC input - FG/DC output: 50MΩ min.	At 500VDC
	Leakage Current	0.2mA max. (100VAC)/0.4mA max. (200VAC)/0.5mA max. (240VAC) *Characteristic data: Fig.8	IEC60950 compliant
EMC	Line Noise Immunity	±2000V (pulse width of 100/1000nS, cycle period of 30 to 100Hz, Normal/Common mode with Positive/Negative polarity for 10 minutes)	There shall be no fluctuation of DC output or malfunction.
	Electrostatic Discharge	EN61000-4-2 compliant	
	Radiated, Radio-Frequency, Electromagnetic Field	EN61000-4-3 compliant	
	Fast Transient Burst	EN61000-4-4 compliant	
	Lightning Surge	EN61000-4-5 compliant	
	Radio Frequency Conducted Immunity	EN61000-4-6 compliant	
	Power-Frequency Magnetic Field Immunity	EN61000-4-8 compliant	
	Voltage dips/Regulation	EN61000-4-11 compliant	
	Conducted Emission	VCCI-B, FCC-B, EN55022-B compliant *Characteristic data: Fig.9, 10	Measured by single unit
	Harmonic Current Regulations	IEC61000-3-2 classA compliant	At rated input/output
Others	Safety Standard	UL60950-1, CSA60950-1 (c-UL) approved, PSE (Ordinance Item 2) compliant, CE Marking (IEC62368-1)	
	Cooling System	Forced air cooling: thermal-sensing variable speed fan embedded	The speed changes with the temperature and the load condition.
	Output Grounding	Connected chassis (FG)	
	Output Hold-up Time	AC cut-off →PWR_OK hold up 16ms min. *Characteristic data: Fig.15	At rated output
	Reliability Grade	FA (Industrial equipment grade to use double-sided PWBs with through holes)	Following our standard
	MTBF	70,000 H min	Based on EIAJ RCR-9102
Weight	2.0 kg typ		
Warranty	Three years after delivery. If any defects belong to us, the defective unit shall be repaired or replaced at our cost.	Except for errors caused by operation not specified in this specification.	

<Fig.1> Low input voltage derating

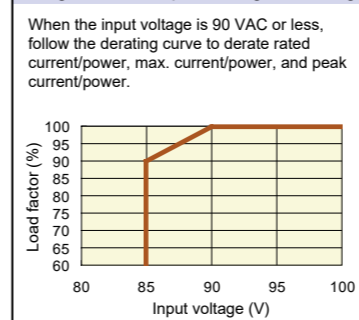

<Fig.2> Duty Ratio

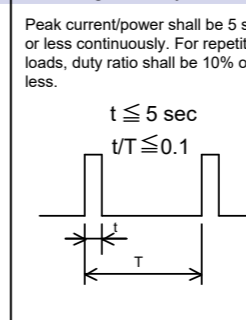

<Fig.3> Temperature Derating

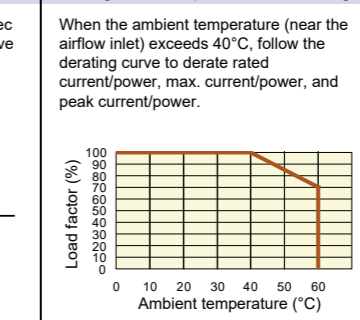

<Fig.4> Min. load condition

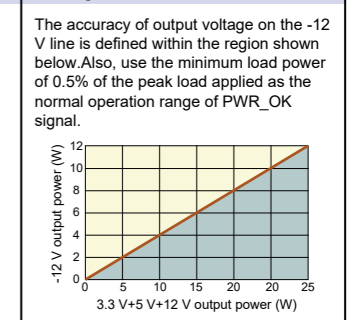

Signal Input/Output Specification (Items are provided at normal temperature and humidity unless otherwise specified.)

Items	Specification	Note
Input Signal	Output ON/OFF control signal (PS_ON#)	+3.3V, +5V, +12V and -12V outputs shutdown with 'H' or 'OPEN' input.
	+3.3V SENSE *1	The input terminal to detect the voltage of +3.3V output; by connecting to the load terminal, only the line drop of the + side of the output cable is compensated.
	FAN control signal (FAN_C)	The control terminal of fan motor; the fan motor is forcibly rotated at full speed at 'L' input.
Output Signal	Normal output signal (PWR_OK)	'H' signal is delivered at normal output. (detection delay time: 100 to 500ms)
	Fan monitoring signal (Fan_M)	Two cycle pulses per one rotation of the fan motor are delivered (open collector output). Duty ratio of the pulse shall be 0.5 typ. (Interval between the signals becomes longer at low speed and shorter at high speed.) The signal remains 'L' or 'OPEN' when the fan stops caused by any failure or malfunction.

Signal Circuit			
Input Signal Circuit	(PS_ON#)	FAN_C signal input circuit	Output Signal Circuit
			<div style="display: flex; justify-content: space-around;"> <div> <p>(PWR_OK)</p> </div> <div> <p>(FAN_M)</p> </div> </div>

*1 Connect the +3.3 V SENSE signal to CH1 (+3.3) at the load end. The CH1 (+3.3 V) output may not satisfy the specification. For further information on the communication specifications of HPCSA-700P-E2S-IoT, contact Nipron.

Sequence Timing Chart

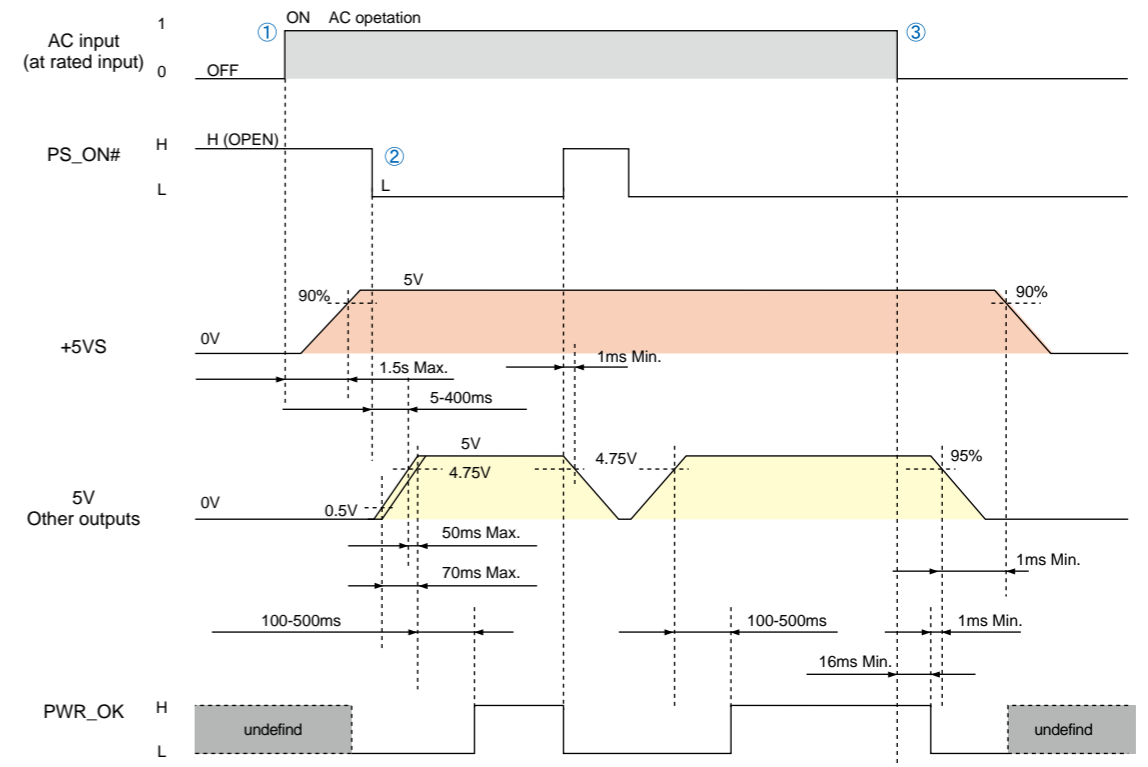

- Only +5VSB output starts up by supplying AC input while PS_ON# is "H" status.
- All outputs start up by inputting PS_ON# 'L'. PWR_OK 'H' is delivered at 100-500 ms after +5V output starts up.
- At blackout, PWR_OK 'L' is delivered after 16ms or more. After that, +5V shut down after 1ms or more.

- Other outputs are also equivalent to the sequence time chart of 5V except for the voltage values. The rise time difference of 5V and other output voltages shall be 50ms or less. The output voltage level at rising of +5V and +12V1-12V3 shall higher than that of +3.3V. However, the order and difference in level of output voltage for each output voltage at falling shall not be specified.
- Rise time of PWR_OK signal shall be 10ms or less. (provided that capacitive load is not connected to PWR_OK signal output)

Internal structure

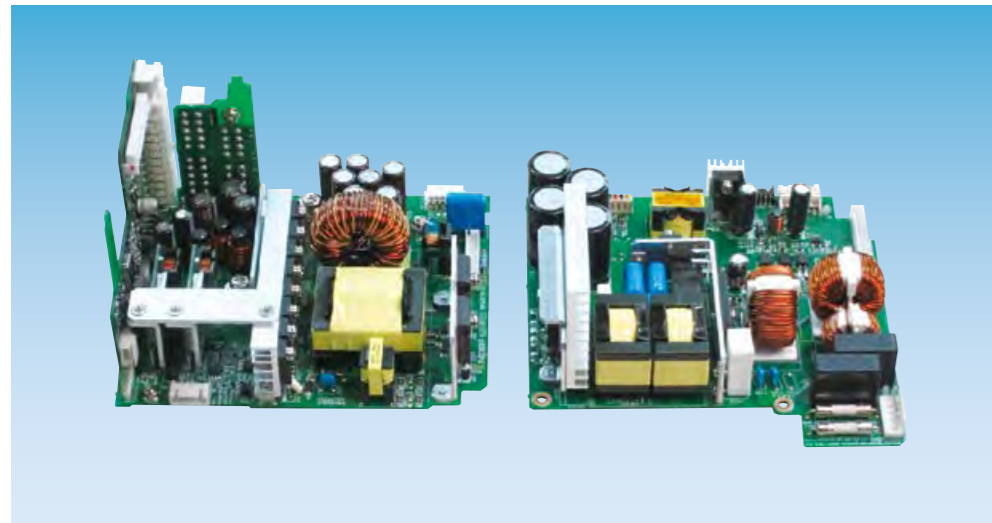

Block Diagram

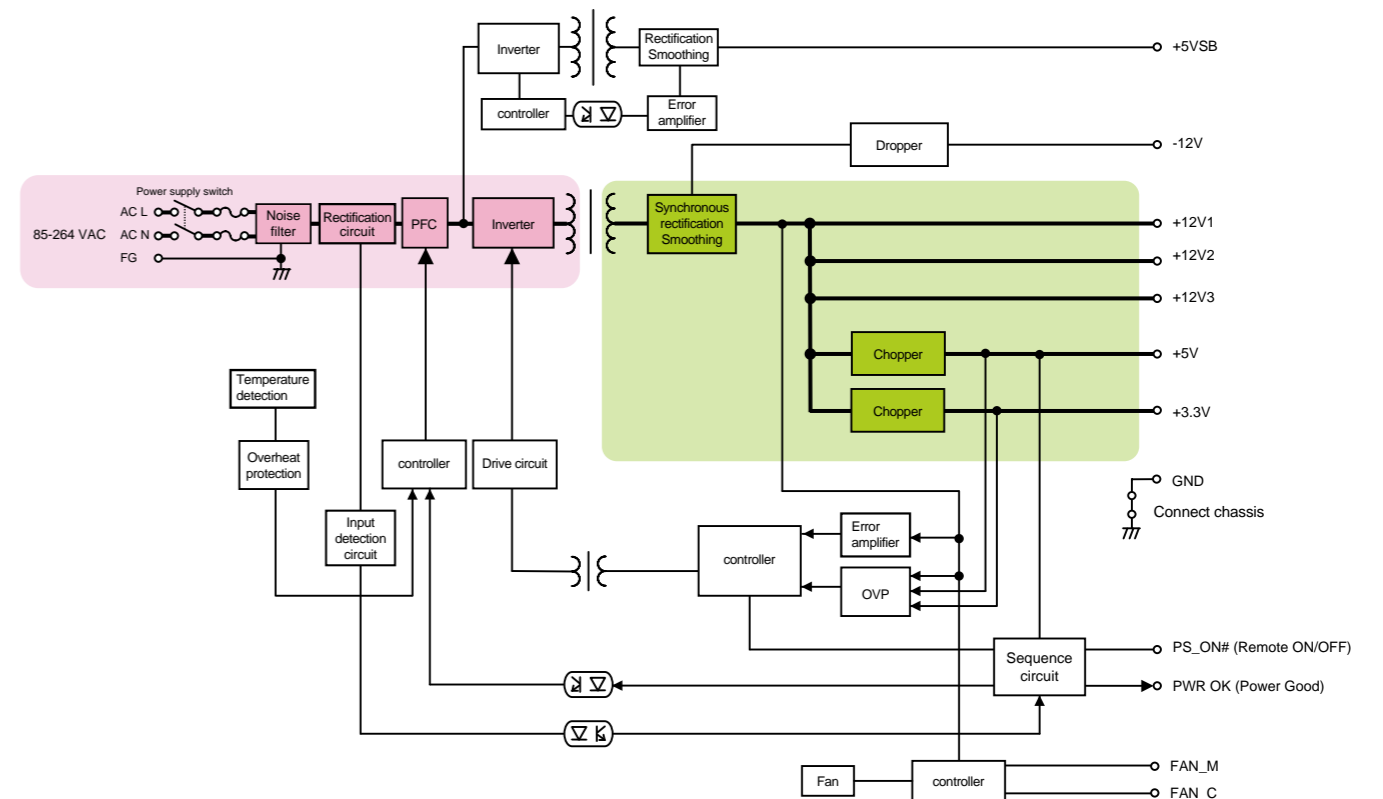

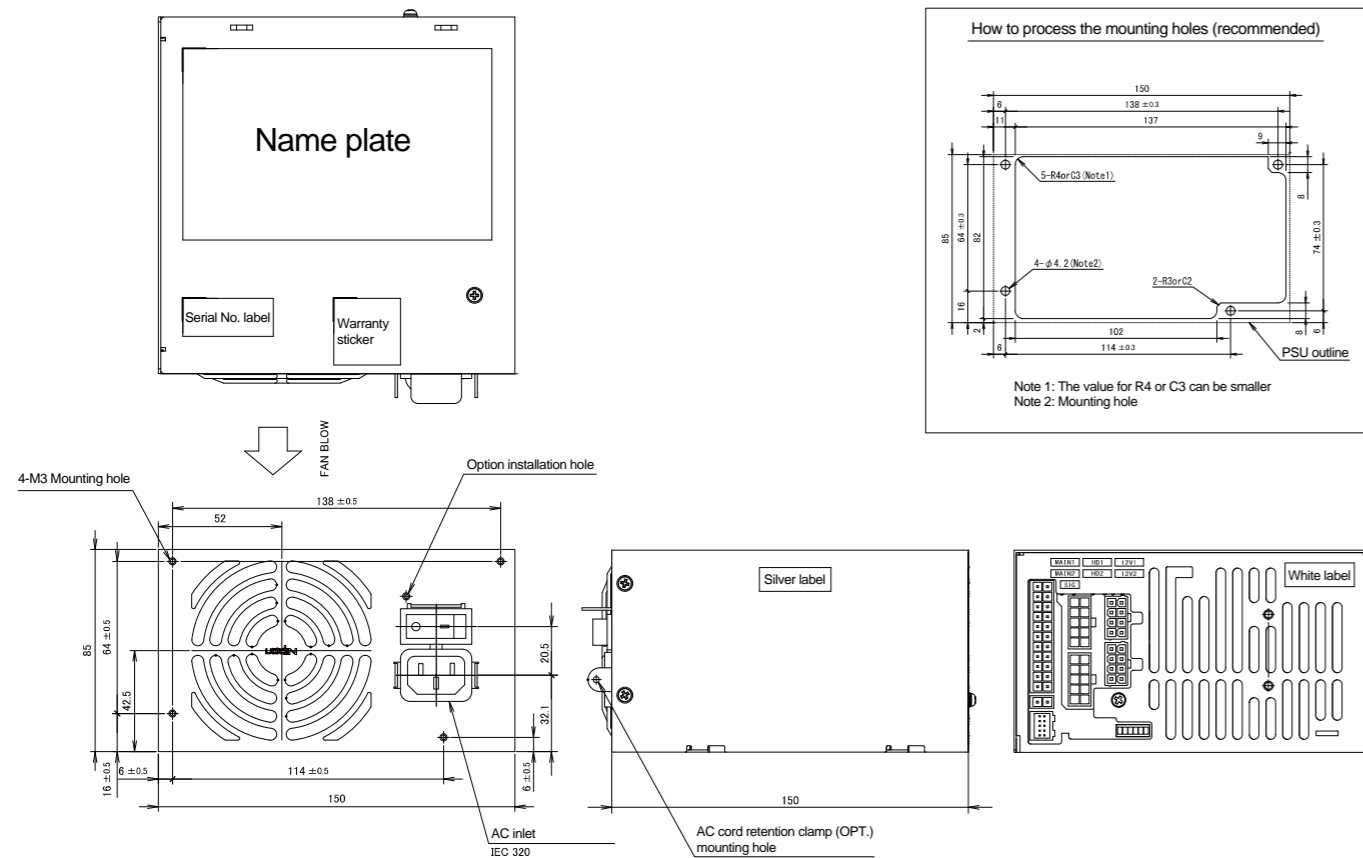

*1 Dimensional tolerance shall be ± 1mm unless otherwise specified.
 *2 The screw depth of penetration into PSU is 5mm max.

Pin assignment

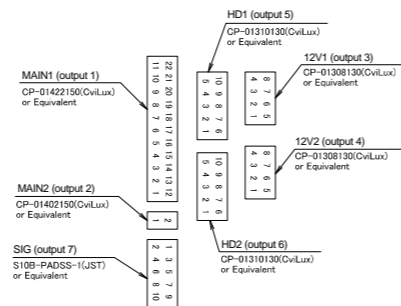

Detachable output harness		Length and type of connector		Output port allocation
Model				
Main power cable MAIN				
WH-M2022-500	500±10	20Pin		
WH-M2022-300	300±10	20Pin		
WH-M2422-500	500±15	24Pin		
12V power cable 12V				
WH-V0808-500	500±15	12V 8Pin		
WH-V0408-500	500±15	12V 4Pin		
WH-VG208-500	500±15	12V 4Pin PCI-E 6Pin		
WH-VV208-500-02	500±10	12V 8Pin 12V 8Pin		
WH-VG208-500-02	500±10	12V 8Pin PCI-E 6Pin		
WH-G0808-500	500±10	PCI-E 6+2Pin		
WH-GG208-500	500±10	PCI-E 6Pin PCI-E 6+2Pin		
HD power cable HD				
WH-PP610-850	550±15	150±15	150±15	Peripheral (HD)
WH-PS610-850	550±15	150±15	150±15	FD
WH-PS710-850	550±15	150±15	150±15	SATA
WH-PS810-1000	550±15	150±15	150±15	150±15
SIG cable SIG				
WH-S0610-500	500±15	SIG-1		
WH-S0610-500-01	500±15	SIG-2		
WH-S0310-500	500±15	SIG-3		

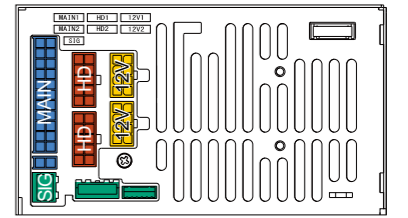

Acceptable cables



Cable			
Photos	Model	Category	Description
	WH6167-02	AC power cord	125VAC 15V (tracking resistance type) [PSE]

Parts			
Photos	Model	Category	Description
	ACC3027	AC power cord retention clamp	AC power cord (WH6167-02) retention clamp

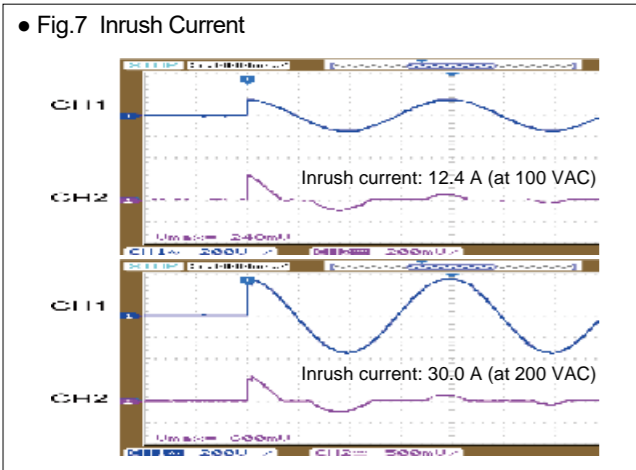
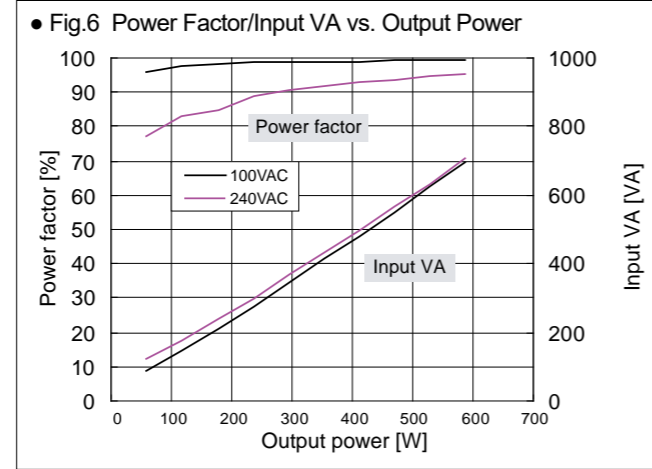
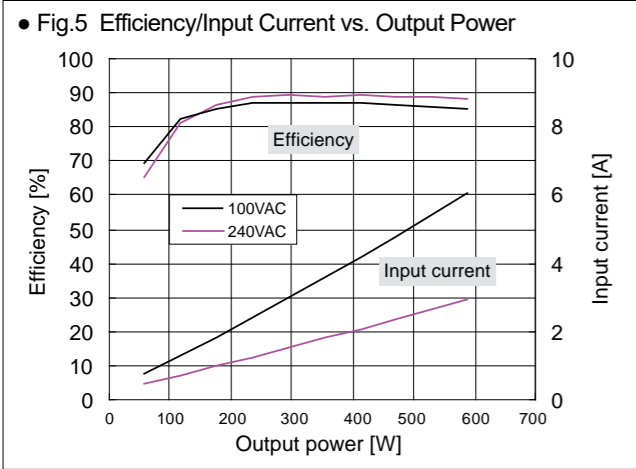

• Fig.8 Leakage Current

Input : 100, 200, 240 VAC
Load : Rated load and Min. load

	Rated load	Min. load
100 VAC	0.10mA	0.10mA
200 VAC	0.20mA	0.20mA
240 VAC	0.24mA	0.25mA

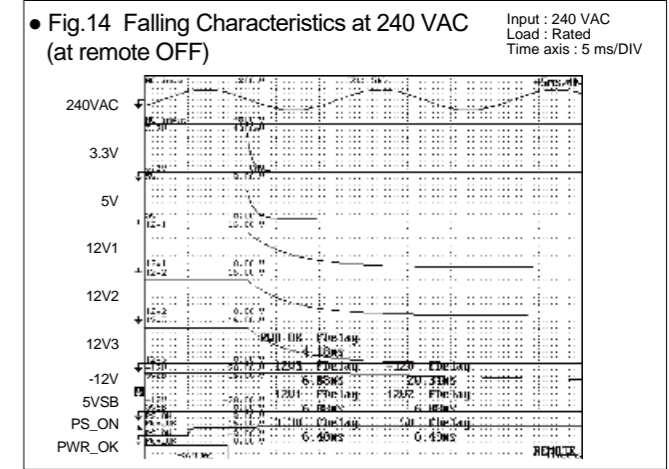
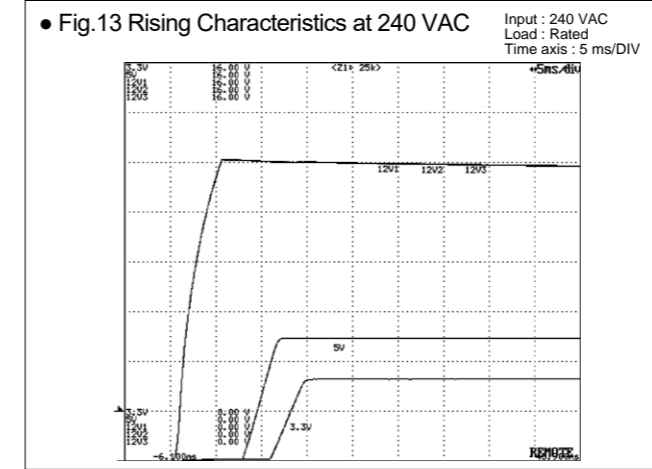
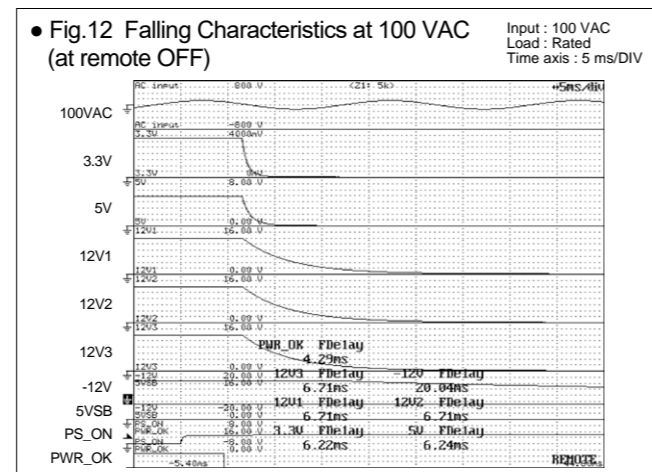
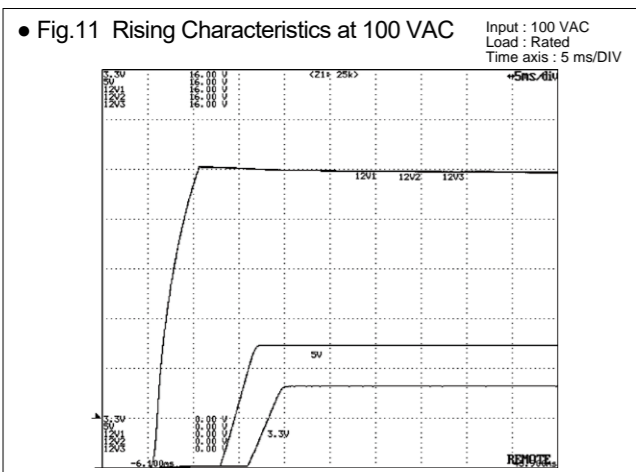
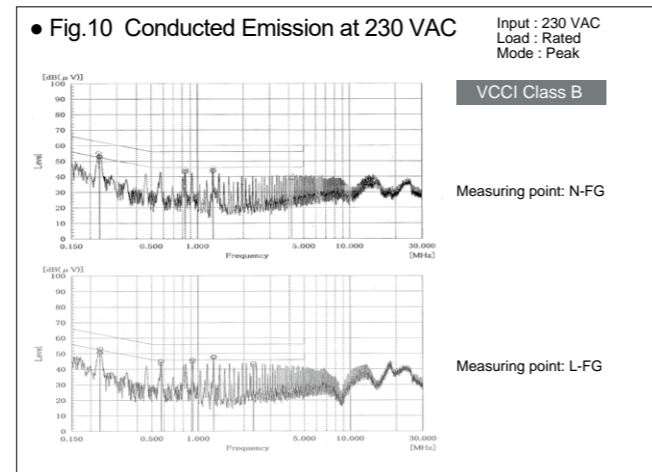
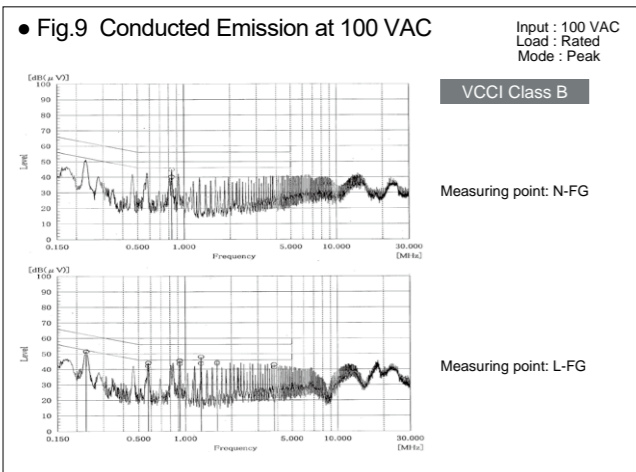

• Fig.15 Output Hold-up Time vs. Output power

PWR_OK: the point that PWR_OK signal "L" is delivered.
Output voltage: the point that output voltage except 5VSB fails down to 95%.

Temp.	Input voltage	Hold-up time	
		PWR_OK	Output voltage
-5°C	100 VAC	19.90ms	22.10ms
	240 VAC	20.50ms	22.70ms
25°C	100 VAC	20.80ms	23.00ms
	240 VAC	21.40ms	23.60ms
45°C	100 VAC	21.00ms	23.00ms
	240 VAC	21.50ms	23.80ms
65°C	100 VAC	35.70ms	37.70ms
	240 VAC	36.70ms	39.00ms

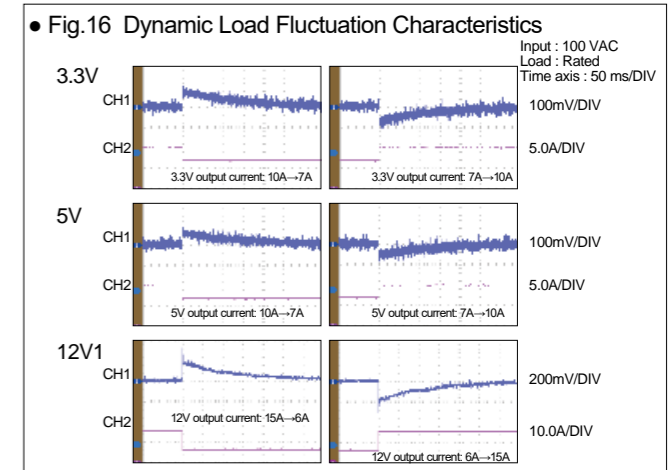

• Fig.17 Output Voltage Regulation (Load Fluctuation)

AC input	85 V	100 V	240V	264V	Output		
					Min. load	Rated load	Load
3.3V output (min.)	3.318 V	3.318 V	3.308 V	3.309 V	0A	15A	
3.3V output (rated)	3.268 V	3.267 V	3.265 V	3.265 V	0A	12A	
5V output (min.)	5.014 V	5.014 V	4.998 V	4.998 V	0A	10A	
5V output (rated)	4.921 V	4.919 V	4.916 V	4.916 V	0A	10A	
12V1 output (min.)	12.054 V	12.054 V	12.059 V	12.059 V	0A	10A	
12V1 output (rated)	11.819 V	11.818 V	11.820 V	11.820 V	0A	10A	
12V2 output (min.)	12.047 V	12.048 V	12.053 V	12.053 V	0A	10A	
12V2 output (rated)	12.803 V	12.803 V	12.804 V	12.804 V	0A	10A	
12V3 output (min.)	12.047 V	12.047 V	12.052 V	12.053 V	0A	10A	
12V3 output (rated)	11.842 V	11.842 V	11.842 V	11.842 V	0A	10A	

• Fig.18 Ripple and Spike Voltage

Load: Rated

Temp	AC Input voltage	+3.3V		+5V		+12V1		+12V2		+12V3		-12V		+5VSB	
		Ripple (mV)	Noise (mV)	Ripple (mV)	Noise (mV)	Ripple (mV)	Noise (mV)	Ripple (mV)	Noise (mV)	Ripple (mV)	Noise (mV)	Ripple (mV)	Noise (mV)	Ripple (mV)	Noise (mV)
-5°C	100V	34.1	74.5	29.4	73.5	19.8	61.8	22.4	55.1	20.6	46.3	45.4	82.7	17.2	39.8
	240V	32.9	70.9	28.6	70.0	19.2	61.5	22.2	54.6	20.2	46.3	45.1	82.2	17.3	39.2
25°C	100V	29.4	66.9	25.9	70.3	19.1	61.9	21.8	56.9	9.2	38.1	46.9	87.2	18.0	37.2
	240V	28.3	65.5	25.4	70.2	19.4	62.9	22.3	59.1	9.2	38.3	46.5	86.5	17.8	38.4
45°C	100V	29.7	67.1	25.4	73.7	19.9	64.3	22.6	61.1	11.3	40.9	45.4	90.2	16.8	31.7
	240V	28.7	68.0	24.9	72.8	20.3	66.6	23.2	61.8	10.1	41.0	45.4	89.2	16.9	35.9
65°C	100V	17.8	59.1	16.8	50.4	14.6	44.5	15.9	45.0	7.2	29.7	28.1	58.6	14.2	29.4
	240V	17.4	58.9	17.2	50.4	16.9	45.7	16.7	46.5	6.8	29.8	28.5	59.0	15.2	29.6

• Fig.19 Ambient Temperature vs. Lifetime Expectancy

Input : 100 VAC
Load : Rated

■ Electrolytic capacitors

Power supply intake temperature	25°C
Lifetime expectancy (about)	25.2 years

*The lifetime shall be 15 years at longest due to deterioration of sealing plates.

■ FAN

FAN ambient temperature	25°C	30°C	40°C	45°C
Lifetime expectancy (about)	13 years	13 years	13 years	11 years

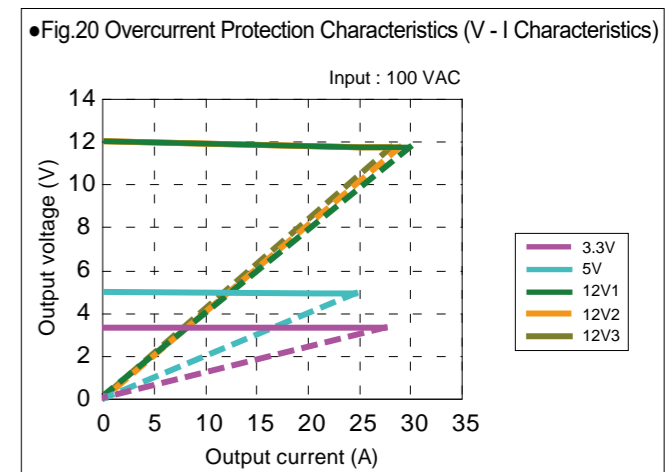



Nipron Co., Ltd.

●Sales department and R&D department
1-3-30, Nishinagasu-cho, Amagasaki-city, Hyogo, 660-0805, Japan.
TEL: +81-6-7220-3657 FAX: +81-6-6487-2212
URL: <http://www.nipron.com/>

w w w . n i p r o n . c o m

●Contact us

- Do not copy. Copyright© 2021 Nipron Co.,Ltd
- Do not use our products for special purposes including nuclear power, airplanes, military, space projects, and anything that directly involves human life.
- Company names, product names and logos in the catalog are trademarks of each company or registered trademarks.
- Specifications, design and prices in the catalog are subject to change without prior notice.
- When using a product, please request for a product specifications and make sure to check all the items for proper use.