

Single Output Power Supply UZP-220 series

Ultra-high efficiency 94%
Various outputs (+12V, +18V, +24V, +48V) with 220W lined up

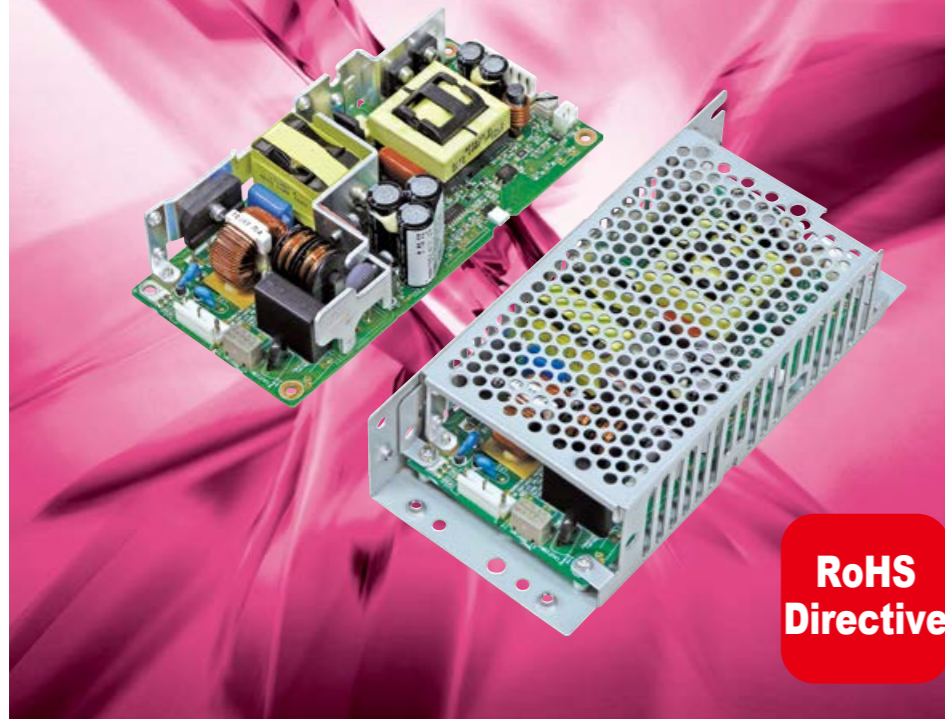

With battery pack connected to UZP-220-**-B*, backup at blackout is available.



■ Battery pack BS28A-H350/2.5L

Single Output	
Continuous	Peak
180W~	400.8W~
220.8W	401.4W

RoHS Directive

Structure and I/O connector	Model	Output voltage	Output current *1	Output power *1
Open frame type/ Nylon connector	UZP-220-12-JBE	+12V	15A (33.4A)	180W (400.8W)
	UZP-220-18-JBE	+18V	10A (22.3A)	180W (401.4W)
	UZP-220-24-JBE	+24V	9.2A (16.7A)	220.8W (400.8W)
	UZP-220-48-JBE	+48V	4.6A (8.35A)	220.8W (400.8W)

Structure	Model
With chassis	'C' is added after open frame model name (Ex: UZP-220-12-JBE-C)
With chassis and cover	'K' is added after open frame model name (Ex: UZP-220-12-JBE-K)
Input/Output connector type	Model
Screw terminal block	'J' in the nylon connector model become 'T' (Ex: UZP-220-12-TBE)

■ Model name coding

① Series name	④ 12:12V	⑤ S05:5VSB output	⑦ 0:Without backup function	⑨ Modification
② Peak output	18:18V	S12:12VSB output	B:With backup function	⑩ Blank/Without chassis and cover
③ Output power	24:24V	Blank/Without SB output	⑧ Reduction of standby power:	C:With chassis
	48:48V	⑥ Input/Output connector	E:Reduction of standby power function equipped (at RC signal OFF)	K:With chassis and cover
		J:Nylon connector		
		T:Screw terminal block		

*1 Values in () above show peak current and power.

Features

- Blackout backup is possible.
- Low standby power (at RC signal OFF, 0.02Wtyp/100V AC, 0.09Wtyp/200V AC)
- Support ErP directive Lot6 at standby power output equipped type.
- Equipped with a variable resistor to adjust output voltage.
- Low noise and low leakage current eliminates the need for an external noise filter.

Safety standard	UL	CSA	EN	CE	CCC
Reliability grade	HFA	FA	HOA	QA	

Function



Input

AC input	85-264V AC (Worldwide range)
----------	------------------------------

*Some DC input-only types are also available. (Please contact us for details.)

Dimension

W×H×D (mm)	Without chassis and cover	75×36×160
	With chassis and cover	83.8×45×188

An amazing high level of efficiency 94% has been achieved for a 24V output type.

(*At 230V AC input, 220W load)

400W peak power, approx. over 180% higher than continuous rated.

Standby power output (5VSB/12VSB) equipped model is also added.

General Specification (Items are provided at normal temperature and humidity unless otherwise specified.)

Items	Specification	Measurements conditions, etc.				
AC Input	Rated Voltage	100-240VAC (85~264VAC)	Worldwide range *See <Fig.1> Low input voltage derating below.			
	Input Frequency	50-60Hz	Frequency range 47-63Hz			
	Efficiency	100VAC 90.0% typ (12V/18V output), 91.5% typ (24V/48V output) 200VAC 92.0% typ (12V/18V output), 93.5% typ (24V/48V output)	At 180W output (convection cooling) *Characteristic data: Fig.5			
	Power Factor	100VAC 99% typ 200VAC 90% typ	*Characteristic data: Fig.6 At rated output (convection cooling)			
	Inrush Current	17A typ (100VAC), 34A typ (200VAC) *Characteristic data: Fig.7	Power thermistor system at cold start (25°C)			
	Input Current	100VAC 2.1A typ (at 12V/18V output, convection cooling), 2.4A typ (at 24V/48V output, convection cooling) 3.0A typ (at 12V/18V output, forced air cooling), 3.8A typ (at 24V/48V output, forced air cooling) 200VAC 1.1A typ (at 12V/18V output, convection cooling), 1.2A typ (at 24V/48V output, convection cooling) 1.6A typ (at 12V/18V output, forced air cooling), 1.5A typ (at 24V/48V output, forced air cooling)	*Characteristic data: Fig.5 At rated output			
Output	Model	UZP-220-12	UZP-220-18	UZP-220-24	UZP-220-48	
	Rated Voltage	+12V	+18V	+24V	+48V	
	Continuous Rated Output1 (convection cooling)	15A	10A	9.2A	4.6A	At rated input Refer to <Fig.4> output derating on the following page.
	Continuous Rated Output2 (forced air cooling)	21A	14A	13.8A	6.9A	
	Peak Current/Power	252W	252W	331.2W	331.2W	*Refer to peak output power condition below. Convection cooling and forced air cooling
	Factory Setting	33.4A	22.3A	16.7A	8.35A	
	Adjustable Voltage Range	400.8W*	401.4W*	400.8W*	400.8W*	
	Static Input Regulation	12V±2%	18V±2%	24V±2%	48V±2%	At rated output
	Static Load Regulation	-5%, +10%	-5%, +10%	-5%, +20%	-5%, +10%	At continuous rated output1
	Temperature Regulation	48mV max.	72mV max.	94mV max.	192mV max.	
Protection	Over Current Protection	100mV max.	125mV max.	150mV max.	300mV max.	
	Method	0.02%/°C max.				
	Recovery	120mV max.				
	Over Voltage Protection	0-70°C	150mV max.	200mV max.	250mV max.	Connect 150mm max. lead wire to output connectors, and then connect a 10µF electrolytic capacitor with a 0.1µF ceramic capacitor in parallel to the other ends of the wires to measure by an oscilloscope with 100MHz frequency band.
	Method	-10-0°C	180mV max.	400mV max.		
	Recovery	101% min. of peak rated current				
	Reclosing of AC input	Blocking oscillation *Characteristic data: Fig.20				
	Reclosing of AC input	Automatic recovery				
	Reclosing of AC input	Output shutdown (latch lock)				
	Reclosing of AC input	Reclosing of AC input				
Environment	Operating Temp./Humidity	13.8-16.2V				
	With Chassis and Cover	22.0-26.0V				
	Storage Temp./Humidity	30.0-35.0V				
	Storage Temp./Humidity	56.2-63.0V				
Vibration	-10-70°C (at convection cooling), -10-70°C (at forced air cooling) *1/20-90%				*<Fig.3> on the next page shows the guideline of forced air cooling. Refer to <Fig.4> output derating.	
Mechanical Shock	-10-60°C (at convection cooling), -10-70°C (at forced air cooling) *1/20-90%				There shall be no condensation	
Insulation	Dielectric Strength	-20-85°C/10-95%				Follow JIS-C-60068-2-6 at no operation
	Insulation Resistance	To endure the vibration acceleration of 2G with vibration frequency of 10 to 55Hz for 10 sweep cycles in each X, Y, Z direction.				Follow JIS-C-60068-2-31 at no operation
	Leakage Current	Lift one bottom edge of the unit 50mm high with the opposite edge placed on the test bench, and let it fall. Repeat 3times for each of four bottom edges, and no malfunction shall be observed.				
	Leakage Current	3kVAC/1minute between input and output/RC 2kVAC/1minute between input and FG 500VAC/1minute between each output /RC/FG				Cut-off current 10mA Cut-off current 10mA Cut-off current 100mA
EMC	Line Noise Immunity	50MQmin. between each input/output/RC/FG				At 500VDC
	Electrostatic Discharge	0.06mA typ (100VAC), 0.12mA typ (200VAC) *Characteristic data: Fig.8				
	Radiated, Radio-Frequency, Electromagnetic Field	±2000V (pulse width of 100/1000nS cycle period of 30 to 100Hz, Normal/Common mode with Positive/Negative polarity for 10 minutes)				Measurement by INS-410 There shall be no fluctuation of DC output or malfunction.
	Fast Transient Burst	EN61000-4-2 compliant				Apply to FG and case. There shall be no malfunction, nor failure.
	Lightning Surge	EN61000-4-3 compliant				
	Radio Frequency Conducted Immunity	EN61000-4-4 compliant				
	Power-Frequency Magnetic Field Immunity	EN61000-4-5 compliant				
	Voltage dips/Regulation	EN61000-4-6 compliant				
Conducted Emission	EN61000-4-11 compliant					
Others	Harmonic Current Regulations	VCCI-B, FCC-B, CISPR22-B, EN55022-B compliant *Characteristic data: Fig.9, 10				At rated input and rated output (convection cooling), with chassis
	Safety Standards	IEC61000-3-2 (edition 2.1) class D, EN61000-3-2 (A14) class D compliant.				At rated input/output
	Cooling System	UL60950-1, CSA60950-1 (c-JUL), CCC (GB4943.1 standard), CE Marking (IEC62368-1) PSE (ordinance clause 2) compliant				
	Output Grounding	Convection cooling/Forced air cooling				
Output Hold-up Time	Capacitor grounding					
Reliability Grade	AC cut-off → 90% of rated voltage within 16ms min.				At rated input, output: 200W (at 24V, 48V), 180W (at 12V, 18V)	
Weight	FA (Industrial equipment grade to use double-sided PCB with plated through hole)				Following our standard	
Warranty	310g typ (without chassis and cover), 530g typ (with chassis and cover)					
	Three years after delivery: If any defects belong to us, the defective unit shall be repaired or replaced at our cost.				Except for errors caused by operation not specified in this specification.	

<Fig.1> Low input voltage derating

Follow the derating below to derate rated current/power.

Peak output power condition

- Duty ratio of peak current shall be 30% or less.
- Energized period of peak current shall be 10 seconds or less.
- Energized period of peak current shall be 5 seconds or less at convection cooling and 50 deg. or higher of ambient temperature.
- The value resulting from the formula below shall not exceed continuous rated current, I_o, after derating specified in the output derating on the following page.

$$\sqrt{(I_p^2 \times D) + (I_m^2 \times (1-D))} \leq I_o$$

I_p = Peak current value
I_m = Min. current value
D = Duty ratio, t/T
t = Pulse width of peak current
T = Cycle
I_o = Continuous rated current specified in output derating

(Note) If the temperature of the power thermistor for limiting inrush current does not rise enough (and its resistance value is too large), such as when the normal average load power is small, the output voltage at peak output might drop about 100 ms. If this might cause any problem, please check the output voltage waveform while the power supply is installed on an actual device at operation.

General Specification (Items are provided at normal temperature and humidity unless otherwise specified.)

<Fig.2> Installation/Air cooling

<Fig.3> Guideline for forced air cooling

Please contact us about the guideline for temperature rise of each component at forced air cooling.

<Fig.4> Output derating

Follow the derating diagram below for output according to ambient temperature and installation direction. In case of using the type with chassis and cover, input voltage range shall be 90V AC or higher, and shall not use in direction (F). Also, forced air cooling condition in the diagram shall be provided that the air flow of 1.5 m/s is applied from the direction shown <Fig.2>.

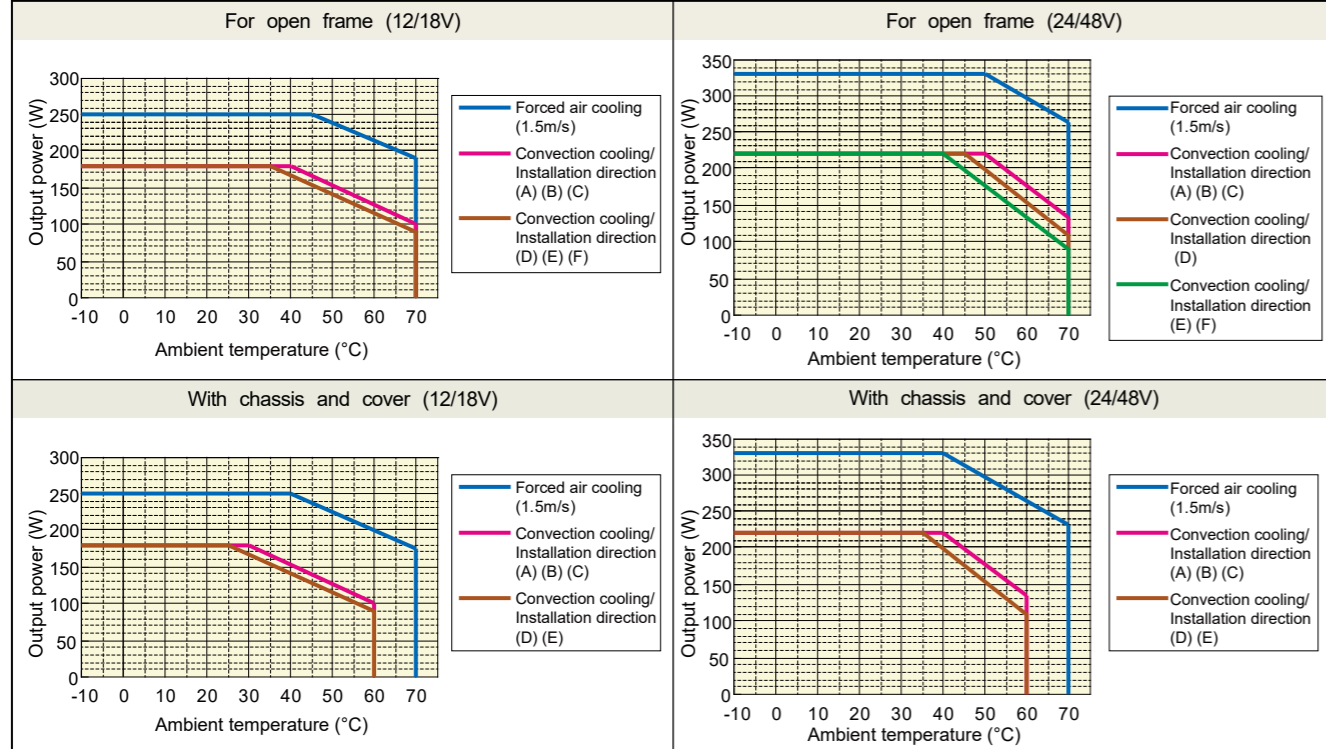

Signal Input/Output Specification (Items are provided at normal temperature and humidity unless otherwise specified.)

Items	Specification	Note								
Input Signal	Output ON/OFF control signal (RC signal) *Remove the shorting plug of CN2 in using RC signal.	<table border="1"> <tr> <th>Operating mode</th> <th>External power supply and Load-limiting resistor</th> </tr> <tr> <td>Between +RC and -RC</td> <td>Output</td> </tr> <tr> <td>SW ON (4.5V or higher)</td> <td>ON</td> </tr> <tr> <td>SW OFF (0.8V or lower)</td> <td>OFF</td> </tr> </table>	Operating mode	External power supply and Load-limiting resistor	Between +RC and -RC	Output	SW ON (4.5V or higher)	ON	SW OFF (0.8V or lower)	OFF
	Operating mode		External power supply and Load-limiting resistor							
Between +RC and -RC	Output									
SW ON (4.5V or higher)	ON									
SW OFF (0.8V or lower)	OFF									
Input Signal Circuit	<table border="1"> <tr> <th>External power supply: E</th> <th>Load-limiting resistor: R</th> </tr> <tr> <td>4.5 ~ 12.5Vdc</td> <td>Not required</td> </tr> <tr> <td>12.5 ~ 30Vdc</td> <td>1.5kΩ</td> </tr> <tr> <td>30 ~ 48Vdc</td> <td>8.2kΩ</td> </tr> </table>	External power supply: E	Load-limiting resistor: R	4.5 ~ 12.5Vdc	Not required	12.5 ~ 30Vdc	1.5kΩ	30 ~ 48Vdc	8.2kΩ	<p>Shorting Plug With shorting plug (CN2) connected, output starts up when AC input is applied regardless of RC signal. To control Start/Stop of output by RC signal, uncap shorting plug of CN2. Note: Shorting plug (CN2) is primary circuit components. Make sure to operate the plug after the AC input is turned off.</p>
	External power supply: E	Load-limiting resistor: R								
4.5 ~ 12.5Vdc	Not required									
12.5 ~ 30Vdc	1.5kΩ									
30 ~ 48Vdc	8.2kΩ									
<p>(RC signal) Connection example: using external power supply</p>										

Sequence Timing Chart

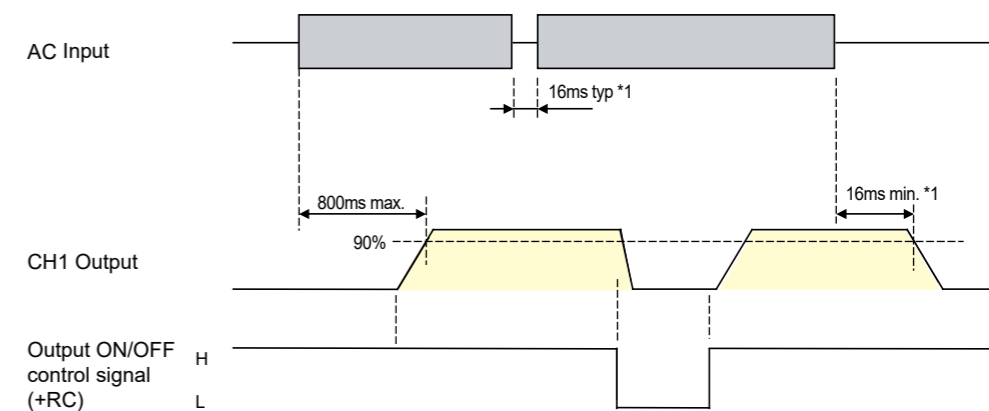

*1 At rated input, output: 200W (at 24V, 48V) / 180W (at 12V, 18V)

Block Diagram

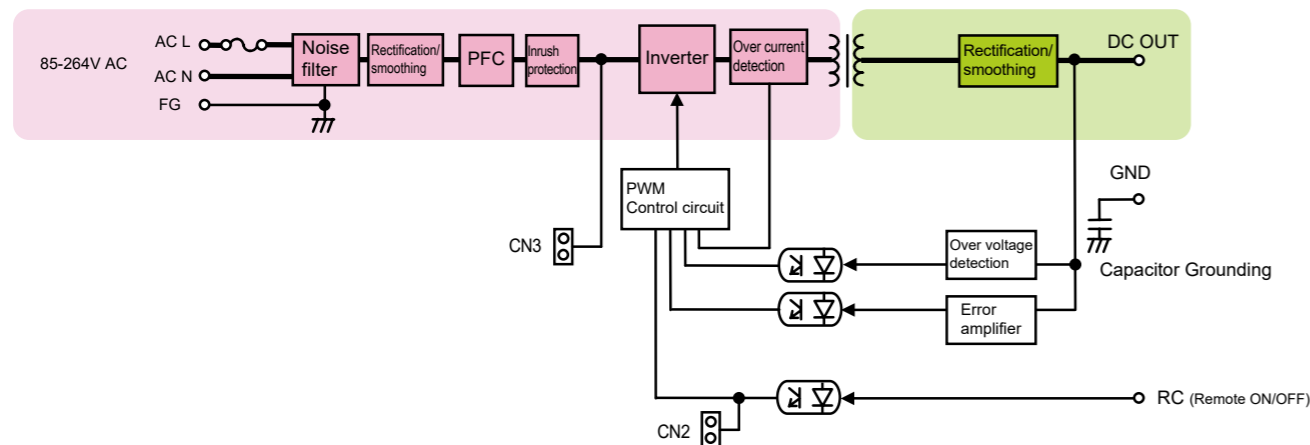

Outline Drawing

PCB type (open frame) model

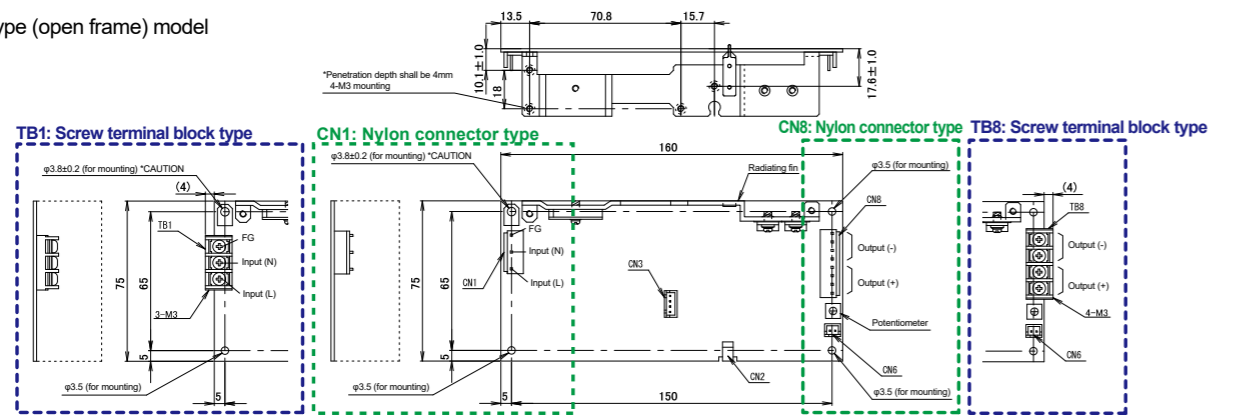

With chassis and cover (Screw terminal block is also available for I/O connector)

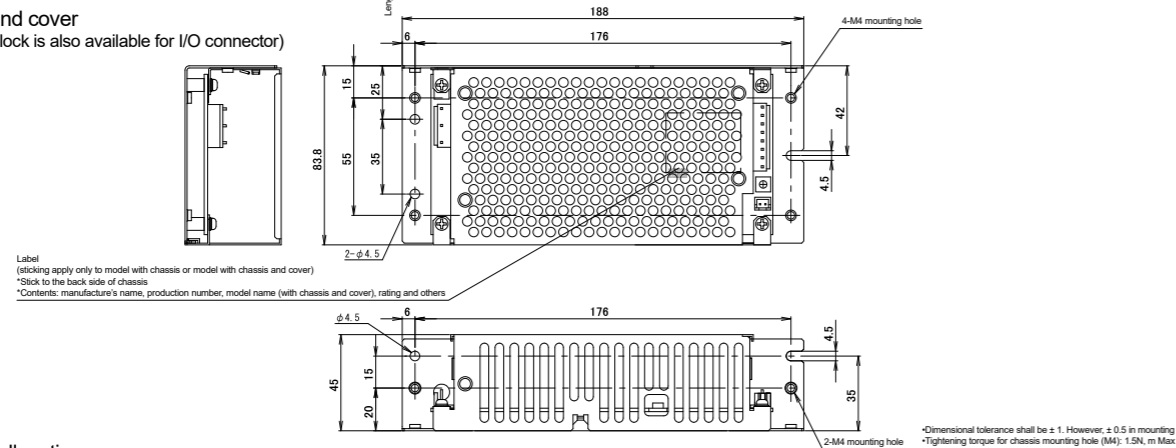

Connector pin allocation

Nylon connector type	Screw terminal block type	Common
<p>CN1 (Input)</p> <p>Applicable housing: VHR-3N (JST) Applicable terminals: Reel: SVH-21T-P1.1(JST) Bulk: BVH-21T-P1.1(JST)</p>	<p>TB1 (INPUT)</p> <p>See the upper outline drawing</p>	<p>CN8 (ON/OFF Control)</p> <p>Applicable housing: XHP-2 (JST) Applicable terminals: Reel: SXH-001T-P0.6(JST) Bulk: BXH-001T-P0.6(JST)</p>
<p>CN8 (Output)</p> <p>Applicable housing: VHR-3N (JST) Applicable terminals: Reel: SVH-21T-P1.1(JST) Bulk: BVH-21T-P1.1(JST)</p>	<p>TB8 (OUTPUT)</p> <p>See the upper outline drawing</p>	<p>CN3 (Capacitor package Input/Output)</p> <p>Applicable housing: XHP-4 (JST) Applicable terminals: Reel: SXH-001T-P0.6(JST) Bulk: BXH-001T-P0.6(JST)</p>

Options (Sold separately)

Capacitor packs and Battery packs				
Photos	Model	Type	Description	Backup time
	BS13A-EC400/422F	Capacitor pack	5 inch bay size	*1
	CB03A-EC400/801F	Capacitor unit		*1
	BS27A-P350/12V	Charging/discharging board for lead-acid battery	Supported a lead acid battery of up to 12V 5Ah	*1, 2
	BS28A-H350/2.5L	Ni-MH	5 inch bay size	*1

*Backup time is just a guideline for first use, and not guaranteed.

*1 The backup time is reference *2 Reference when GS Yuasa's lead-acid battery, PXL12023 is connected

Options (Sold separately)

Cable	Model	Category	Description
	WH-C05VH-800	Input harness	For nylon connector models
	WH-C05VH-800-01	Input harness (with ferrite core)	For nylon connector models
	WH-C08VH-500	Output harness	For nylon connector models
	WH-02XH02XH-500	Signal harness for RC signal	For using the output ON/OFF control signal (RC signal)
	WH-03ELP04XH-200	Power harness for the capacitor pack	For connecting the power supply to the capacitor pack (BS13A-EC400/422F).
	WH-03XH04XH-115	Power harness for the capacitor unit	For connecting the power supply to the capacitor unit (CB03A-EC400/801F). Length: 115mm
	WH-03XH04XH-350	Power harness for the charging/discharging board	For connecting the power supply to the charging/discharging board (BS27A-P350/12V) or the capacitor unit (CB03A-EC400/801F). Length: 350mm
	ACC6198	Shorting connector for startup	For enabling blackout backup (operation of the discharging circuit) by connecting to the charging/discharging board (BS27A-P350/12V).
	WH-09ELP04XH-200	Power harness for connecting the battery pack	For connecting the power supply to the battery pack (BS28A-H350/2.5L).
	WH-S0610-500	Harness for TTL communication	For automatically shutting down the system at blackout. Connect to the battery pack (BS28A-H350/2.5L).
	WH-S1005-500-02	Harness for RS232C communication	For automatically shutting down the system at blackout. Connect to the battery pack (BS28A-H350/2.5L). *The pin allocation is different from "WH-S1005-500-03". (See P10 for details.)
	WH-S1005-500-03	Harness for RS232C communication	For automatically shutting down the system at blackout. Connect to the battery pack (BS28A-H350/2.5L). *The pin allocation is different from "WH-S1005-500-02". (See P10 for details.)

Connection in Series and Parallel

Series operation

Series connection is available as in figure (1) and (2) on the right. Series connection between different output voltages is available, such as 12 V and 24 V.

Note: In the case that different voltages are connected in series as in figure (1) on the right,

- The output current shall be the rated current or less of the smaller rated current among the PSU1 and PSU2 connected in series.
- Connect diodes for protection as show in the figure (1). The rated current of the diodes shall be 1.5 times or more of the peak output current of the power supply which has larger peak output current among PSU1 and PSU2. Also, use Schottky diodes whose forward voltage is lower than the forward voltage of the diodes used in the PSU.

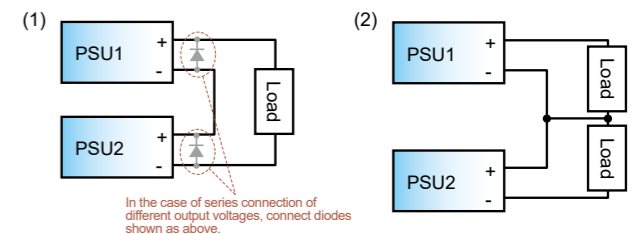

Parallel operation

Parallel operation is not possible.

Characteristics Data (Typical features of the product series) **UZP-220-24** (Examples of actual measurement)

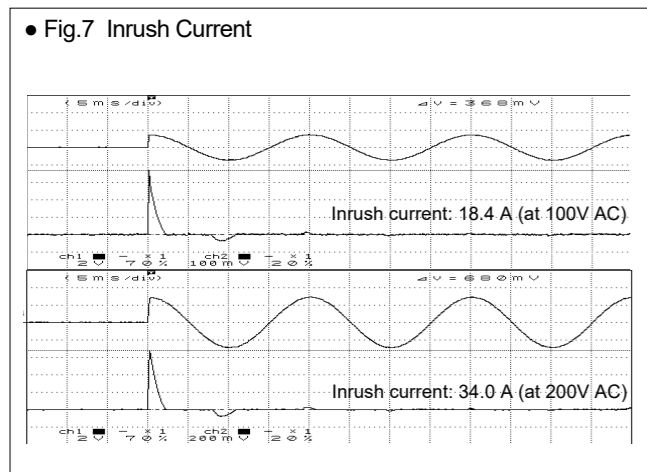
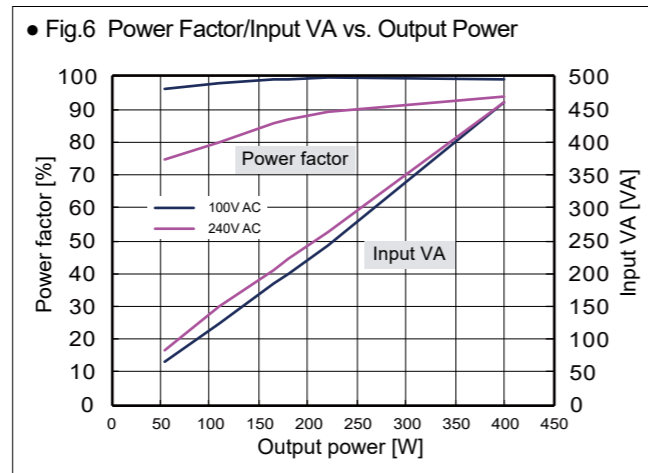
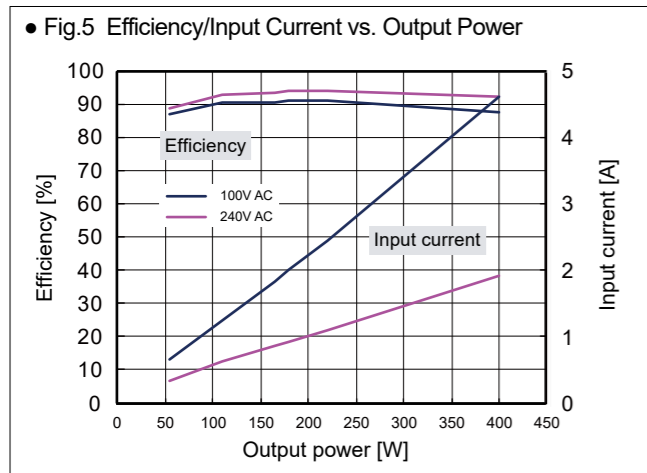

• Fig.8 Leakage Current

Input : 100, 200, 240V AC
Load : Rated load and Min. load

	Rated load	Min. load
100V AC	0.05 mA	0.06 mA
200V AC	0.11 mA	0.12 mA
240V AC	0.14 mA	0.14 mA

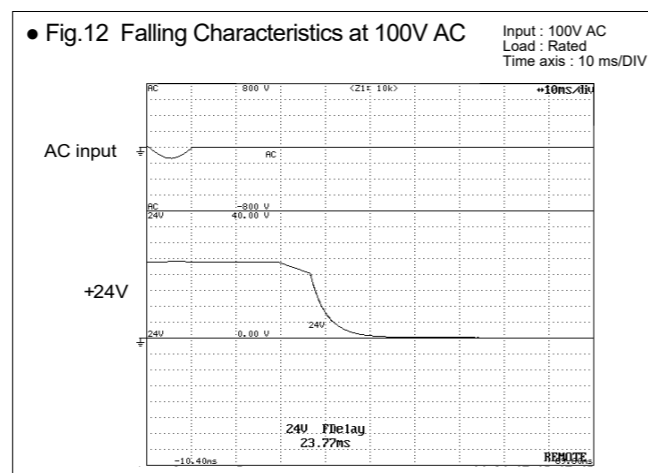
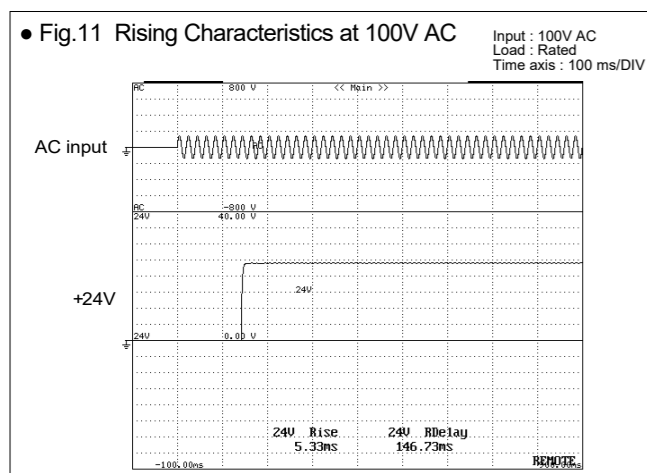
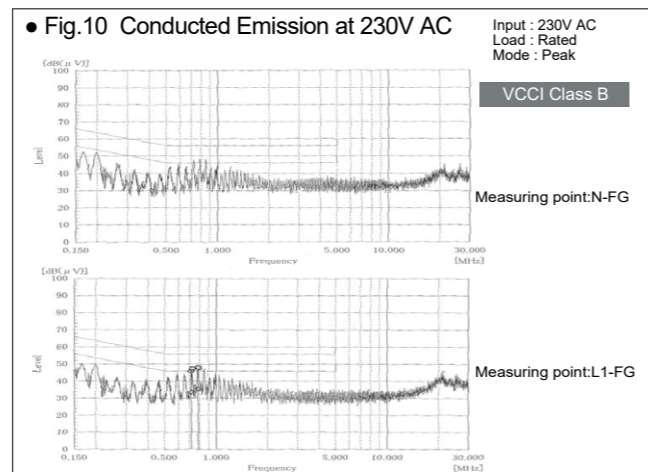
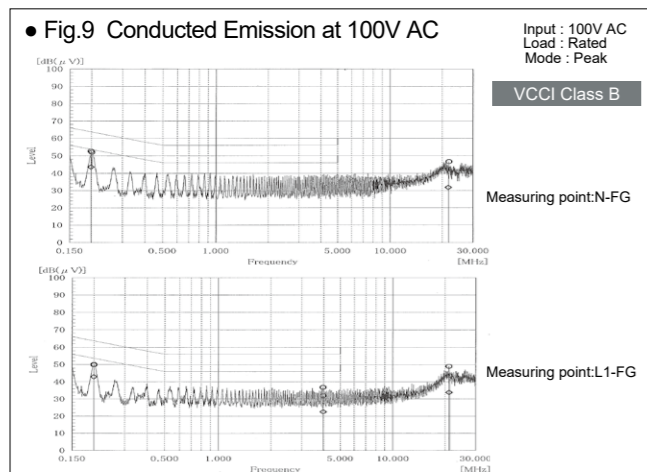

Characteristics Data (Typical features of the product series) **UZP-220-24** (Examples of actual measurement)

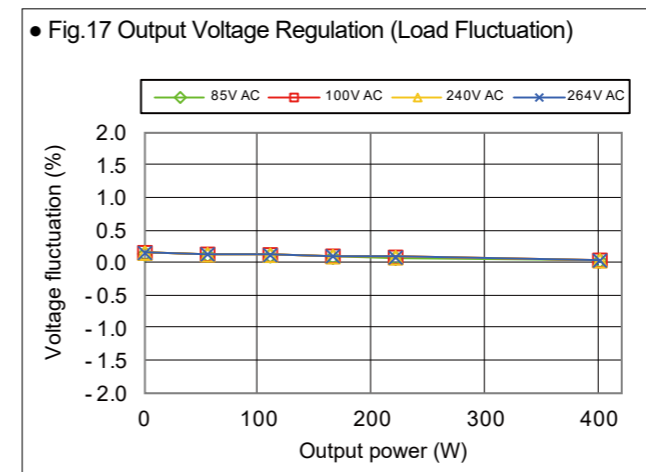
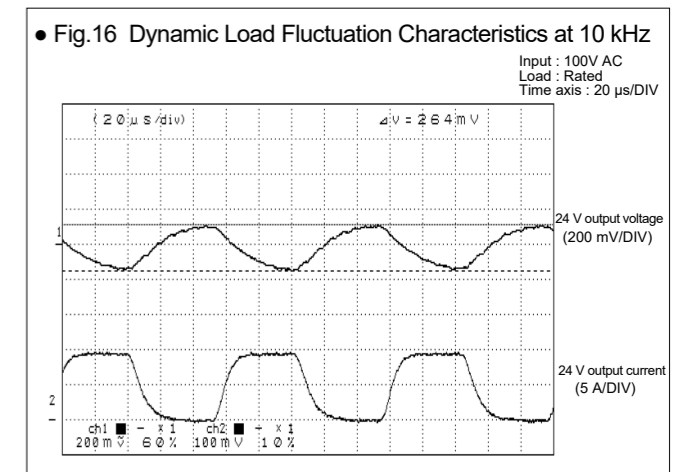
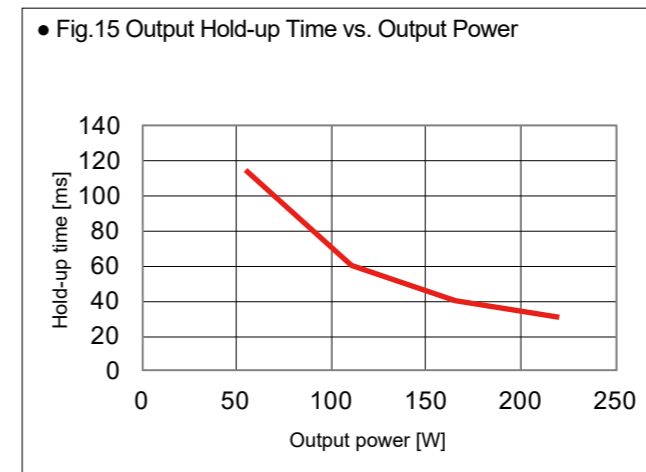
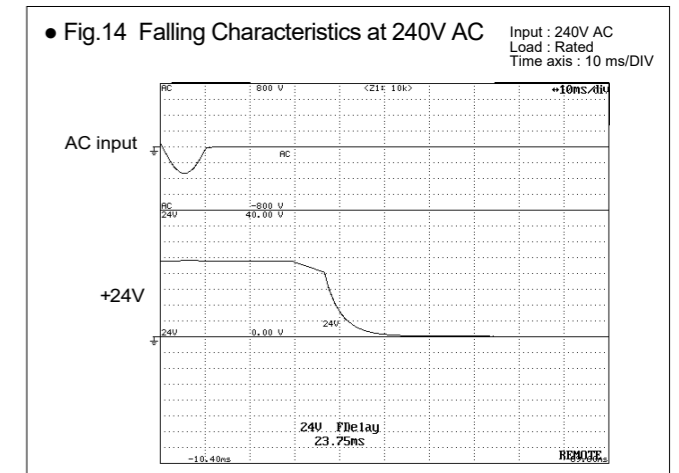
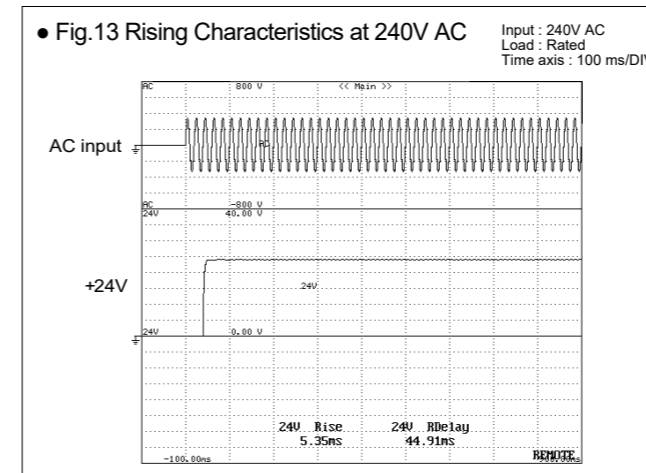

• Fig.18 Ripple and Spike Voltage

Spike voltage
Load : Rated

Temperature	Input voltage	24V
-15°C	100V AC	40.4 mV
	240V AC	31.7 mV
25°C	100V AC	121.0 mV
	240V AC	110.9 mV
55°C	100V AC	99.8 mV
	240V AC	95.3 mV
75°C	100V AC	101.7 mV
	240V AC	97.5 mV
75°C	100V AC	66.2 mV
	240V AC	64.5 mV

